

# IGLÙ<sup>PLUS</sup> H 35 cm

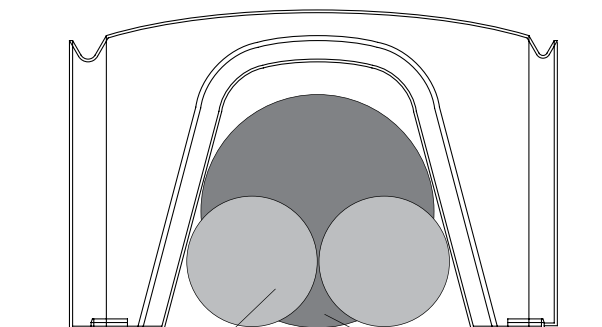

Ventilated under-floor cavities for civil and industrial buildings that are being built new or reconstructed. - Urban infrastructure structures: squares, sidewalks, sports facility. - Creation of an intermediate slab or roofing for cavities used for ventilation and the passage of systems. - Rooms used for humidity and temperature control: drying cells, cold rooms, greenhouses, storage rooms and cellars. - Underground pipes for the passage of utilities. Inspectionable cavities and pits. - By filling it in simply with expanded clay, it can be used to create roof-top gardens. - Underground ducts for the dispersion of water and for drainage. - Overhead sidewalks for passenger loading and unloading or the creation of floating floors. - Levelling height.

Made of ALAPLEN® CP30

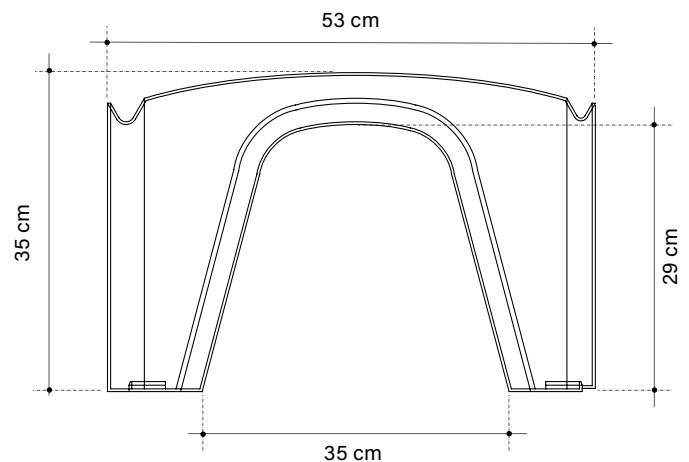
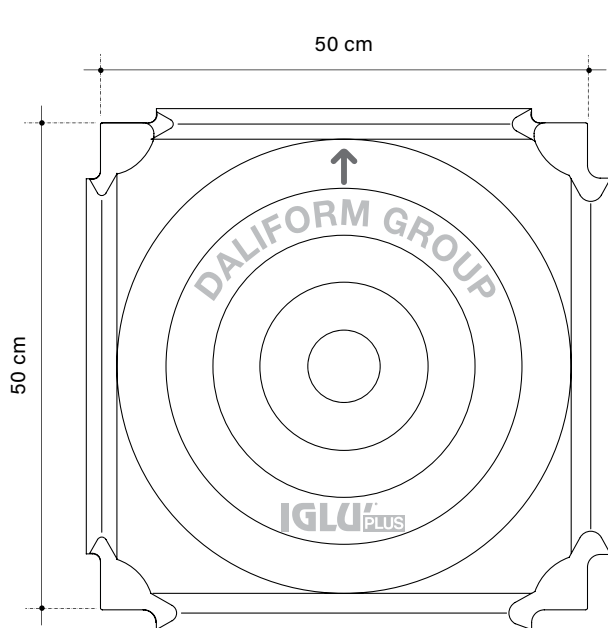

Passage of  
nr. 2 tubes Ø 145 mm

Passage of  
nr. 1 tube Ø 255 mm

The images are only for examples.  
 Recyclable material is allowed a size tolerance of  $\pm 1,5\%$ .



**0,056 m<sup>3</sup>/m<sup>2</sup> Quantity (of concrete to the crown)\*\***

\*\* The volume may vary depending on the pouring condition and the tolerance of the material.

## PRESSURES AT THE BOTTOM OF THE STRUCTURE

IGLU'® PLUS h 35 cm

Loads <sup>[1]</sup> kN/m <sup>2</sup>	Slab cm	Mesh Ø mm cm x cm	Thickness of the lean concrete cm	Pressure at pillar base <sup>[2]</sup> MPa
18	4	Ø5 / 25 x 25	5 10 15	0,162 0,080 0,048
55	5	Ø6 / 15 x 15	10 15 20	0,215 0,127 0,084
110	8	Ø8 / 20 x 20	15 20 25	0,245 0,161 0,114

<sup>[1]</sup> Characteristic values

<sup>[2]</sup> Project values (Ultimate SLU Limit State - Coefficients A1)

The table expresses, starting from the various examples of overload and of thickness (to be given to the slab), the pressures that would be applied to the feet of the structure, in relation to the (eventual) thicknesses of the lean concrete. The overload hypotheses are indicated in table as an example; the actual load capacity is far superior.

To know the exact values or sizing as shown in the project, contact the technical department.

The Technical Office is available to provide planning support both in the preliminary and in the executive phase to determine the technical characteristics of the structures, the related construction costs and perform comparative analyzes with alternative technical solutions. Upon request, it is also possible to take advantage of technical assistance on site.

## TECHNICAL DATA

IGLU'® PLUS H 35 cm

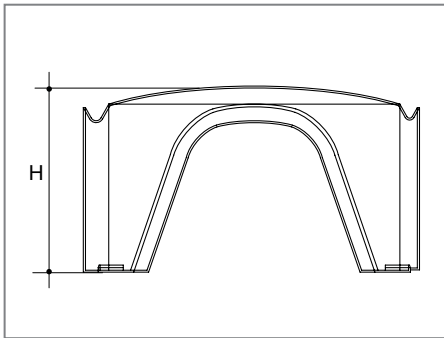

Useful size*	cm	50 x 50
Height H*	cm	35
Quantity of concrete to the crown**	m <sup>3</sup> /m <sup>2</sup>	0,056
Average piece weight	kg	2,044
Pallet dimensions	cm	110 x 110 x 231 h
M <sup>2</sup> pallet	pz/m <sup>2</sup>	75
Pieces per pallet***	pz/PAL	300
Pallet weight***	kg/PAL	626

\* Recyclable material is allowed a size tolerance of  $\pm 1,5\%$ .

\*\* The volume may vary depending on the pouring condition and the tolerance of the material.

\*\*\* For production necessity the technical data can be change.

## DRY ASSEMBLY METHOD

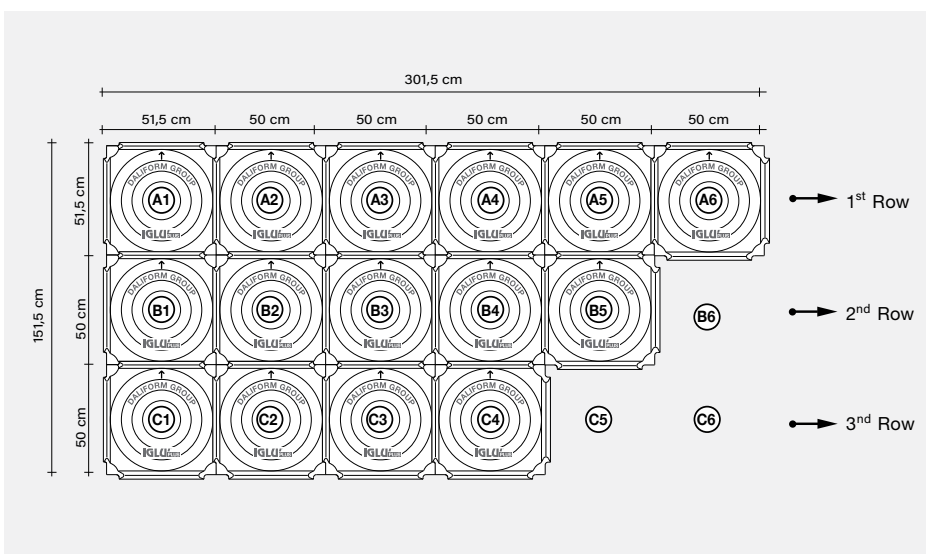

⚠ To ensure a correct installation and perfectly created under-floor cavity please refer to the product's usage requirements.

Dry-stone time-exposure of IGLU'®: 80 m<sup>2</sup>/h

## TECHNICAL PACKING AND TRUCKING



1 pallet: 4 piles of 75 pieces

Pieces for pallet: 300

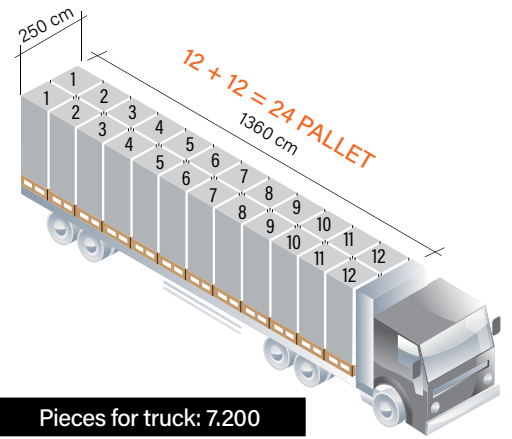
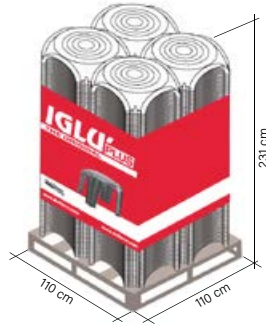

Pieces for truck: 7.200

## LABELLING

Each pallet is identified with:



A coloured band containing:  
the brand, a type image of the product,  
the Company name, the website and  
any warnings.



A label with the following informations: product's  
name and code, quantity, Certificate of the  
Environmental Compatibility, date of production, shift  
of production, n° of the worker, production line batch.

## CREDITS

- BBA;
- Declaration of Performance Conformity;
- Hygienic certificate;
- Acoustic check for verification of DIN standards;
- Avis Technique;
- Rupture load tests;
- Productive process monitoring tests;
- Certificate of Environmental Compatibility.

The product does not fear the weather and can be stored outside. Take the utmost care to prevent the product from being deformed or overstressed during the unloading, storage and assembly. In case of disposal the product is totally recyclable.

## ACCESSORIES

### CASTING STOP L-PLAST

Useful size	cm	205 x 33,5+5+5+5+6,5
Thickness	cm	0,40
Piece weight	kg/pc	0,820
Package	m	50



### CASTING STOP PIBIStop

Max Height	cm	30+5+5+5+5
Max Width	cm	40
Thickness	cm	0,40
Package	pc	25

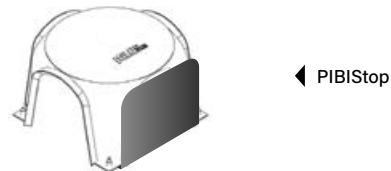

### EXTENSION

Width	cm	33
Depth	cm	min. 10 max. 50
Height	cm	32

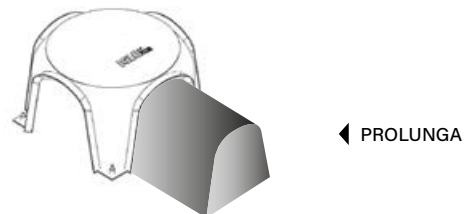

### ISO IGLU'

Useful size	cm	100 x 100
Thickness	cm	3+5 / 3+10
Piece weight	kg/pc	1,25 / 1,70
Package	pc/PAL	16 / 12



### BETON UP

Useful size	cm	29 x 29
Thickness	cm	0,30
Piece weight	kg/pc	0,284
Package	pc/box	100

